

RULE MANAGEMENT GROUP

THE VOLVO OPEN 70 RULE

PUBLIC INTERPRETATION NO.21

This public interpretation is given in accordance with rule 1.3 of the Volvo Open 70 Rule Version 2

Question:

On the mast drawing below are 3 fittings that all extend outside the maximum dimensions of the mast. These fittings are rigidly fixed to the mast tube. On the side-walls of the mast tube are padeyes, with the lower padeye arrangement having a backing/packing plate. At the aft face of the mast tube is a gooseneck / vang fitting.

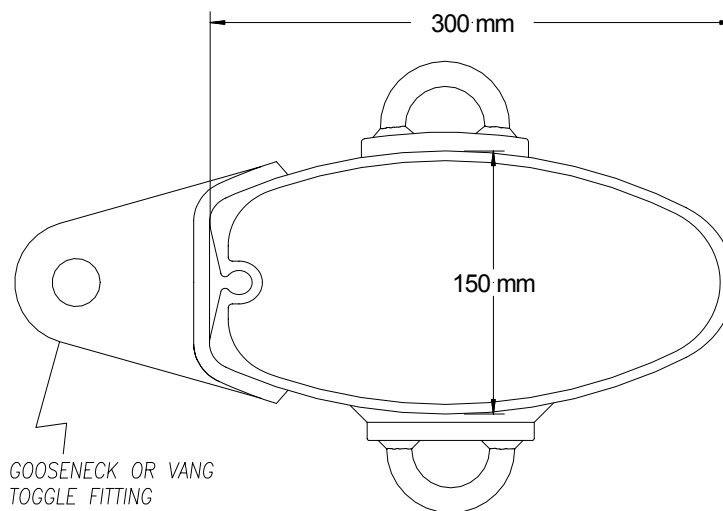

MAST CROSS SECTION BELOW IG

1. Does a mast with such fittings comply with rule 6.1.1(c)?

Interpretation:

Rule 6.1.1(c) states *“Other than local stiffening, the external mast dimensions below the top of IG (see rule 6.2.5) shall not be less than 300mm fore and aft by 150mm wide, or greater than 375mm fore and aft by 180mm wide.”*

1. Yes. The external mast dimensions are related to the mast tube only. Additional fittings and external local stiffenings/reinforcements are not included in the measurement of these mast dimensions, with the exception of any mast groove or track as specified in rule 6.1.1(d).

END

Signed on behalf of the Volvo Open 70 Rule Management Group

James Dadd, Chief Measurer
6th November 2007